

ARTICULATED ARM

BOBEASY
CAB CONTROL

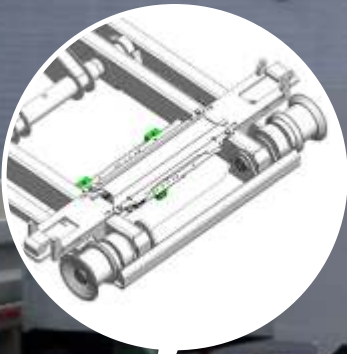

HYDRAULIC
EXTERNAL LOCKING



UNDERFRAME PIERCED
LONGITUDINAL
MEMBERS



ELECTRO HYDRAULIC
FLOW CONTROL WITH
EMERGENCY LEVERS

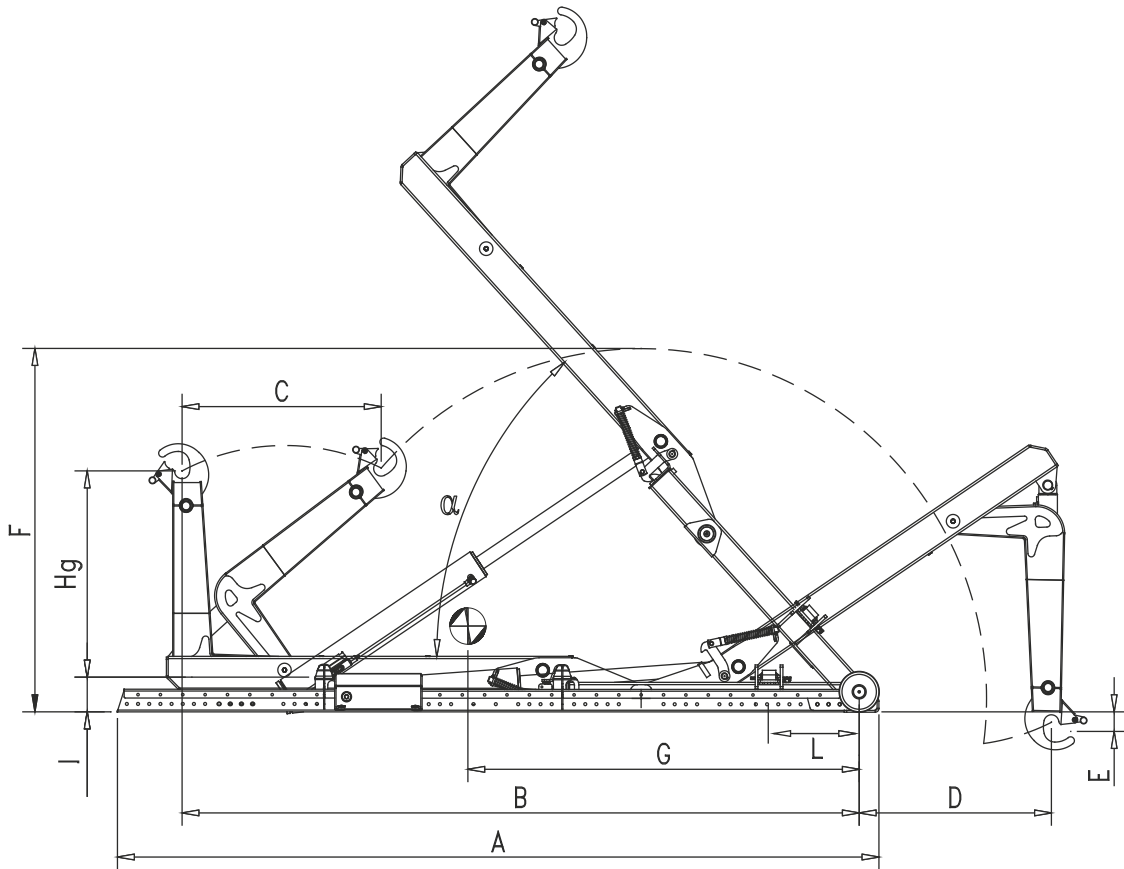

MODEL	A 9.000 XC	A 9.000 XC	A 9.000 N	A 9.000 L
Hg	35.63" (905 mm)			
A	104.72" (2.660 mm)	116.53" (2.960 mm)	124.4" (3.160 mm)	132.28" (3.360 mm)
B	95.47" (2.425 mm)	107.28" (2.725 mm)	119.09" (3.025 mm)	125.98" (3.200 mm)
C	34.64" (880 mm)			31.49" (800 mm)
D	25.59" (650 mm)	23.62" (600 mm)		21.65" (550 mm)
E	7.87" (200 mm)	3.93" (100 mm)	1.96" (50 mm)	3.93" (100 mm)
F	54.72" (1.390 mm)	59.05" (1.500 mm)	62.99" (1.600 mm)	66.92" (1.700 mm)
Weight*	1.012 lb (460 Kg)	1.045 lb (475 Kg)	1.078 lb (490 Kg)	1.116 lb (530 Kg)
α	57°	51°	47°	45°
Container min. max.	8' - 10' (2.440 - 3.050 mm)	9' - 11' (2.740 - 3.350 mm)	10' - 12' (3.050 - 3.650 mm)	11' - 13' (3.350 - 3.950 mm)
LIFTING CAPACITY	9.000 lb (4.090 Kg)			
TIPPING CAPACITY	9.000 lb (4.090 Kg)			